

www.ezquerrocatalamuebles.com



ROBERTO

EZQUERRO CATALÁ
MOBILIARIO Y PROYECTOS DESDE 1937

~
Executive Area

- ~
Tabelle
Slim Palette
Diamond
Vita
Palette
A-plus



Tabelle + Executive System



Tabelle + Executive System

“IT’S ALL ABOUT MOVEMENT EVERY MOVEMENT IS AN OPTION, EVERY OPTION, A CONNECTION OF MOVEMENTS!”

Tomadores de decisiones

Si los que toman las decisiones exigen un alto grado de responsabilidad, los conjuntos ejecutivos deberían de favorecer lo mejor posible a los procesos de decisión y votación que les permitan dirigir mejor la empresa en base a objetivos fijados.

La funcionalidad de la instalación de los conjuntos directivos es tan importante como su acabado de alta calidad, ya que los conjuntos ejecutivos simbolizan el rango que se le confiere a este gremio dentro de la organización. Por ello se emplea aquí estructuras de aluminio pulido y, cubierta en chapa de maderas finas y cristales de seguridad cuya precisión y elegancia son inconfundibles.

Decision makers

If decision makers require a high degree of responsibility, executive sets should to promote the best decision-making and voting. for example using a table whose sides istalacion rounded encourage interaction and inter change of meeting participants. The exposed places on the front sides allow better targeting based on company objectives.

The functionality of the installation of officers for suit is as important as its high quality finish as executive sets symbolize the range that gives this guild within the organization. So here is used polished aluminum structures, covered in fine wood veneer and security windows whose precision and elegance is un mistakable.



STRONG IDEA TABELLE

Context matters. From our own experience we know there are places that are uplifting and others that depress us. Space that energise and space that exhaust us. We depend on our surroundings to feel spirited and hopeful. Understanding the modern office first means understanding modern architecture.

El contexto es importante. Desde nuestra propia experiencia sabemos que hay lugares que son edificantes y otros que nos deprimen. Espacios que energizan y espacios que nos agotan. Depende de nuestro entorno para sentirnos alegres y esperanzadores. Entender la oficina moderna significa primero entender la arquitectura moderna.





INTERNATIONAL STYLE TABELLE EXECUTIVE

Tomadores de decisiones. Si los que toman las decisiones exigen un alto grado de responsabilidad, los conjuntos ejecutivos deberían de favorecer lo mejor posible a los procesos de decisión y votación. Por ejemplo durante una instalación de mesas cuyos costados redondeados fomentan la interacción y el intercambio de ideas de los participantes de la reunión. La esquinas expuestas en los lados frontales permiten dirigir mejor la empresa en base a objetivos fijados.



MEETING AREA TABELLE REUNIONES

La elegancia del producto Tabele infunde una particular personalidad también al espacio de reuniones, con una selección de mesas cuadradas o rectangulares de patas robustas, cableables, con acabados en laminados plásticos y/o cristales de color

Mesas de grandes dimensiones, para acoger las reuniones más concurridas, o bien mesas individuales para encuentros exclusivos, siempre con un elemento formal único y reconocible: el perfil triangular de las patas, que crea múltiples juegos de líneas y superficies. Esta es la propuesta del proyecto Tabele para espacio de reuniones, completada con muebles de guarda como credenzas y libreros.



All you need
Is the best thing Tabele.





La recepción es el primer ambiente que expresa la personalidad e imagen de una empresa. Con su estricto minimalismo, Tabelle comunica una atmósfera fina y funcional. Líneas limpias, grandes superficies y volúmenes de diferentes alturas, saludan a los visitantes y satisfacen todas las necesidades de los operadores. Con acabados en laminados plásticos terminados en imitación maderas finas y/o cristales de colores dando vida y una incomparable imagen a sus áreas de bienvenida.

DRAWERS, CAJONERAS, LIBREROS, CREDENZAS:

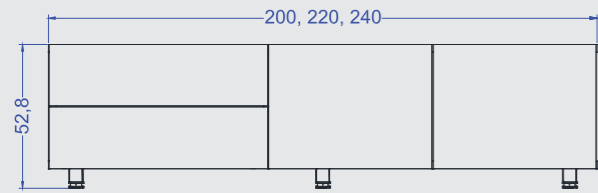

Modulo de T.V. mod: CRTB-001
Modulo multiusos fabricado en melamina con 2 cajones papeleros y 2 puertas. Frontes de cajones y puertas en cristal de color.

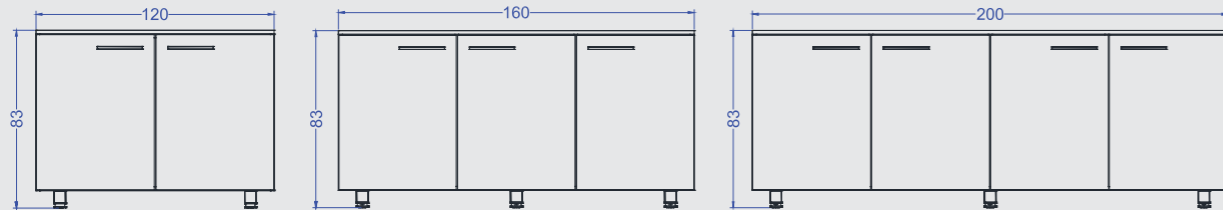

Credenza VTCR-02
credenza fabricada en melamina de 28mm, con puertas en melamina de 16mm recubiertas en cristal de color.

Credenza CRTB-003

Credenza CRTB-004

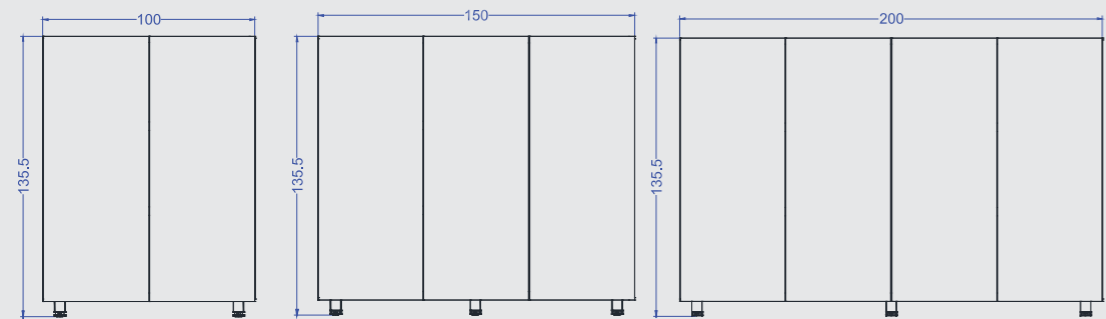

Librero LBTB-001

Librero LBTB-002

Librero LBTB-003

Librero fabricado en cuerpo en melamina de 28mm. con puertas en melamina de 16mm recubiertas en cristal de color.

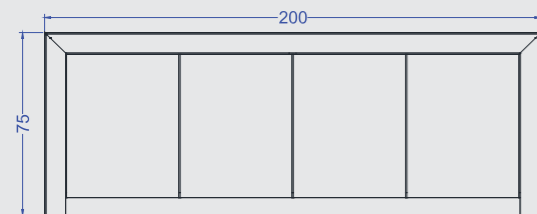

Credenza CRTB-006

Credenza fabricada con cuerpo en melamina con estructura de aluminio recubierta en cristal en su parte superior, costados y puertas. Disponible en 3 y 4 puertas.

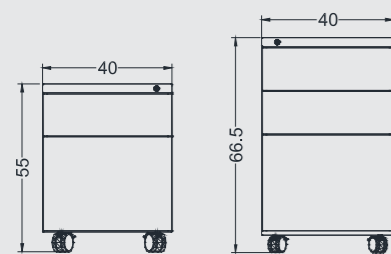

Cajoneras moviles y fijas.

Cajoneras metalicas terminadas en pintura epoxica con jaladeras ocultas y correderas de extension total. colores: blanco, negro y gris.

MEETING, MESAS DE JUNTAS:

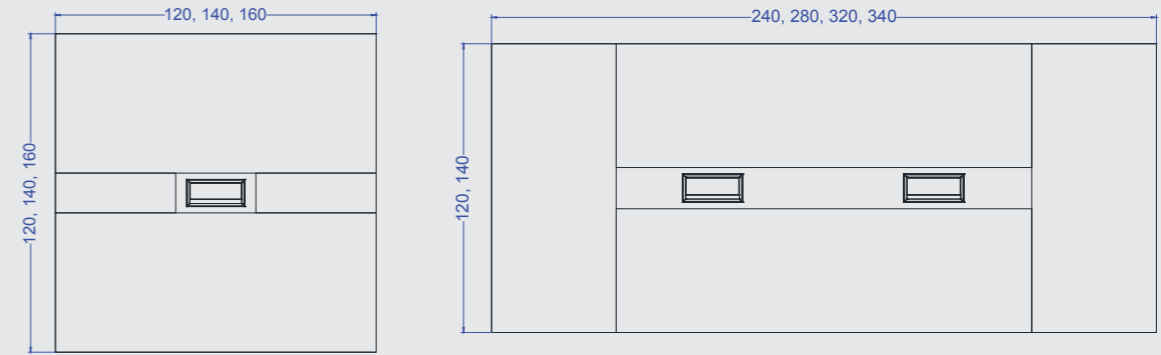

EXECUTIVE DESCK, ESCRITORIO EJECUTIVOS:

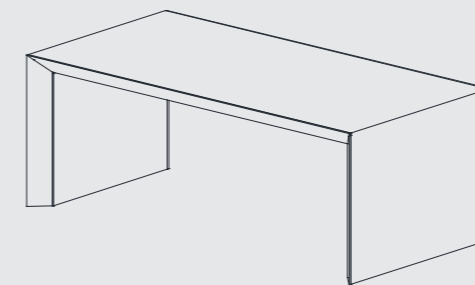

MSTBG-200-100 F200 D100 H75
MSTBG-240-100 F240 D100 H75

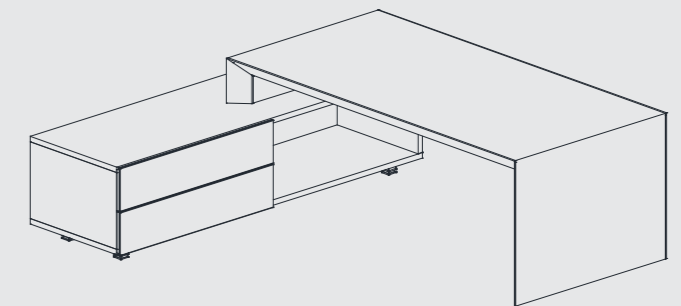

ESTBG 215-200 F215 D200 H75

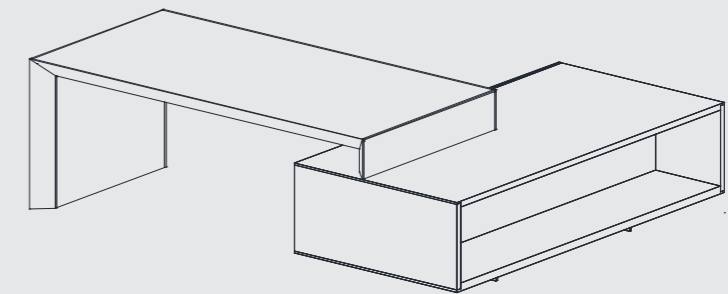

ESTBG 250-200 F250 D200 H75

FINISHES, ACABADOS:

Top, Cubiertas.



Frame, Estructuras.

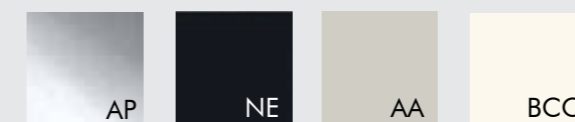



Paulette



ROBERTO
EZQUERROCATALÁ
MOBILIARIO Y PROYECTOS DESDE 1937



Paulette



ROBERTO
EZQUERRO CATALÁ
MOBILIARIO Y PROYECTOS DESDE 1937

Paulette

Slim palette + Executive System





Equilibrio entre innovación, calidad, confort y representatividad, estas son las características principales de Slim Palette. Como en los mejores proyectos, se unen la sabiduría artesanal, diseño y tecnología, el resultado es un producto de inconfundible identidad y carácter.

The main Slim Palette character is the balance between quality and innovation, comfort and representation. As it happen in the best projects, craftsmen knowledge, design and technology gather one to the other, the result is a product of unique identity and character.

Diamond + Executive System





El negro como elemento de decoración y elegancia única, vitta logra espacios de gran diseño y distinción, con su estructura cerrada que se integra perfectamente con sus sistemas de guardas.

Vitta + Executive System



BAUHAUS WALTER GROPIUS

Context matters. From our own experience we know there are places that are uplifting and others that depress us. Space that energise and space that exhaust us. We depend on our surroundings to feel spirited and hopeful. Understanding the modern office first means understanding modern architecture.

1919 when Walter Gropius founded the Bauhaus in Weimar, the later legendary Hochschule für Gestaltung, he defined a turning point in modern architecture. The Bauhaus was attempting to bring together various artistic and technical disciplines. Architecture was understood as a synthesis of the arts.



Vitta + Executive System



INTERNATIONAL STYLE VILLA SAVOYE - LE CORBUSIER

Le Corbusier was one of the most important and influential architects of the 20th Century. He consequently separated load and nonload bearing elements. By using a system of posts no limits were set in designing the floor plans. Instead of the usual high windows, Le Corbusier used wide windows and achieved a significantly better and more uniform exposure.

In the 1920s, Le Corbusier experimented with colours, and their architectural effect. For him, the colour of a building was important as the layout and form.



The executive desking of vitta offers a variety of finishes as plastic laminates, wood veneers, glass, chrome metal structures, painted in white, steel gray and black.





Vitta un sistema ejecutivo,
que nace como respuesta a los
requisitos actuales de los usuarios
y de las empresas que demandan
ergonomía funcionalidad y belleza.

- flow is a state of productive harmony where motivation and attention get together.
- flow ist ein Zustand der Harmonie, wo produktive Motivation und Aufmerksamkeit zu bekommen zusammen.
- débit est un état d'harmonie productive où la motivation et l'attention se réunissent.



El negro como elemento de decoración y elegancia única, vitta logra espacios de gran diseño y distinción, con su estructura cerrada que se integra perfectamente con sus sistemas de guardas.

All you need
Is the best thing Vitta.



NORTH AMERICA
JOHNSON WAX BUILDING
FRANK LLOYD WRIGHT



Frank Lloyd Wright represents the North American point of view in modern architecture. In 1936 he designed the Johnson Wax Building which is a completely introverted building. Rooms are only indirectly exposed through skylights in the walls and ceilings. Inside the building's expressive mushroom-shaped concrete columns support the roof of the large operating room. Wright employed more than 200 kinds of bricks to build his idea of a flow movement of the walls.

Work Station



Sea como mesa de trabajo individual o configurado como puestos múltiples de trabajo, Vitta presenta un extenso abanico de posibilidades para que el cliente diseñe su oficina personalizada según su dinámica de trabajo y necesidades.

whether used as a single desk or configured as multiple user workstation, Vitta offers a wide range of possibilities so that the customer can design his office according to work dynamics and needs.
Flexibility and versatility for today's office.



Feel at home in
your worksapce.

DRAWERS, CAJONERAS Y LIBREROS:

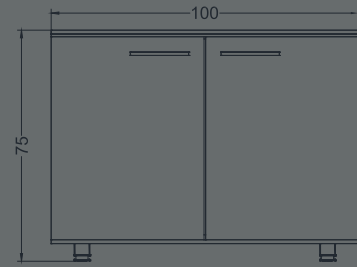

Credenza VTCR-02
credenzas en 2, 3 y 4 puertas fabricadas:
cuerpo en lamina de acero, colores:
blanco, negro y gris.
frentes y tapa superior:
laminado plastico y/o chapa de madera.

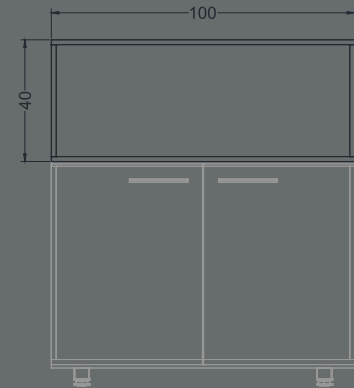

Estante para libros VTEL-100



Librero VTLB-001
Librero fabricado en cuerpo
en lamina de acero colores:
blanco, negro y gris
frentes y tapa superior:
laminado plastico y/o
chapa de madera.



Librero de 4 pueras VELB-004

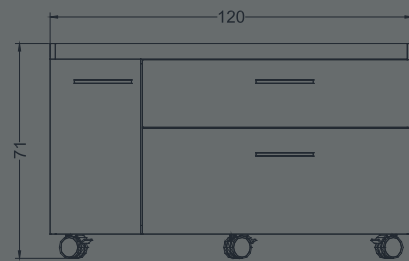

Modulo de archivo con porta CPU
Modelo: VTMA-001

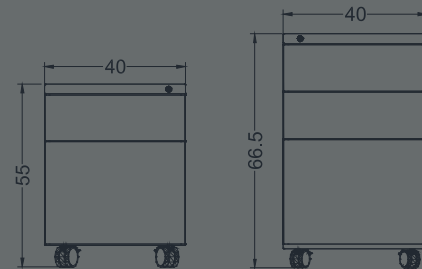

WORKSTATIONS, ESTACIONES DE TRABAJO:

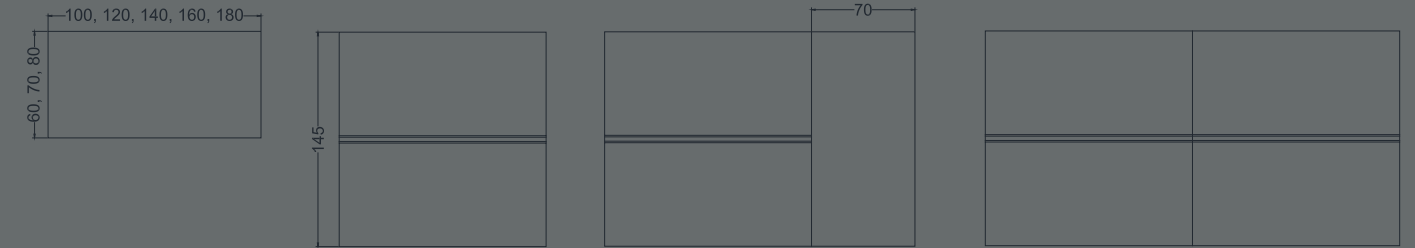

EXECUTIVE DESCK, ESCRITORIO EJECUTIVOS:

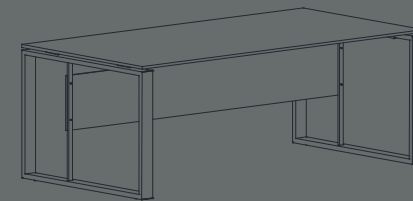

VTEXT-18 F180 D100 H75
VTEXT-20 F200 D100 H75
VTEXT-22 F220 D100 H75

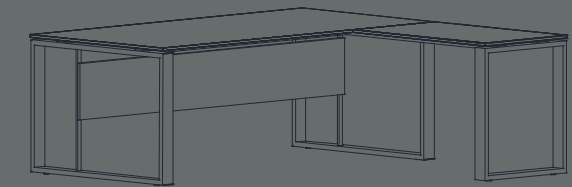

VTETL-18 F180 D180 H75
VTETL-20 F200 D200 H75
VTETL-22 F220 D200 H75

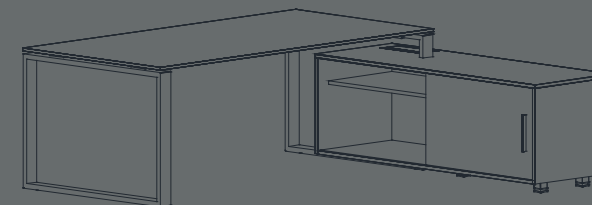

VTEXCTV-18 F180 D180 H75
VTEXCTV-20 F200 D200 H75
VTEXCTV-22 F220 D200 H75

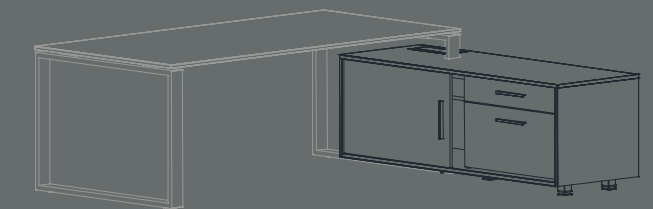

ACCESORIES, ACCESORIOS:

Riel porta accesorios

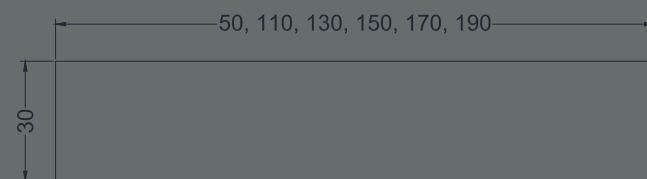
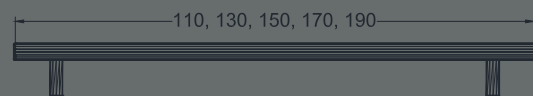

Screens, Pantallas.



Cpu holder, Porta cpu.

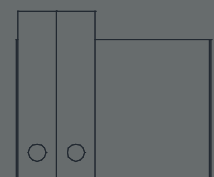

Paper box, Papelera.

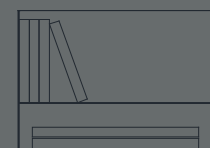

B.

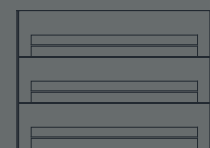

C.

MEETING TABLES, MESAS DE REUNIONES:

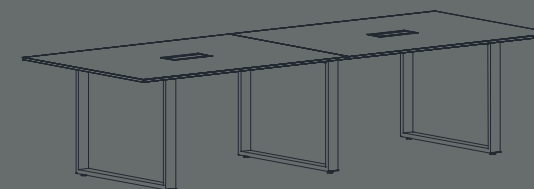

VTMET320 F320 D120 H75

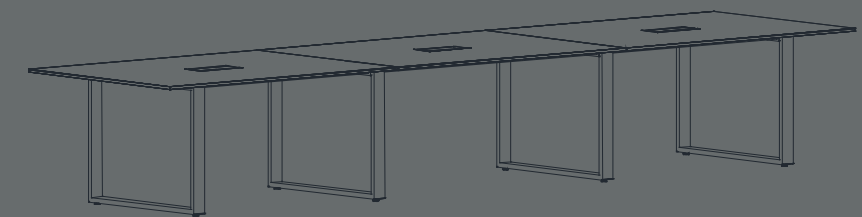

VTMET480 F480 D120 H75

Palette + Executive System



The executive desking of palette offers a variety of finishes as plastic laminates, wood veneers glass, chrome metal structures, painted in white, steel gray and black.



Palette + Executive System



Palette

Design by Marco Colin

The force for office

La consistencia de los elementos diseñados del sistema autosustentable palette, pueden ser usados en áreas de espera, escritorios ejecutivos, mesas de conferencia, etc.





Palette

El cristal negro como elemento de elegancia en la línea palette es inigualable. sus fuertes líneas rectas hacen que los espacios sean agradables y altamente funcionales.



Naturalmente Elegante
Palette.







All you need
is the best thing "Palette"

PALETTE CRISTAL

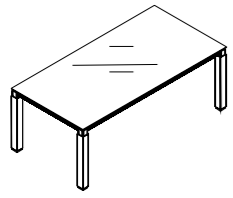

PG-EXC-200-100

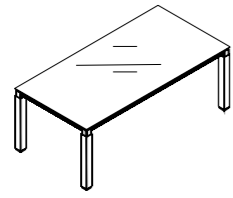

PG-EXC-180-90

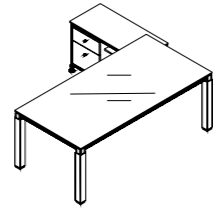

PG-EXC-200-100L

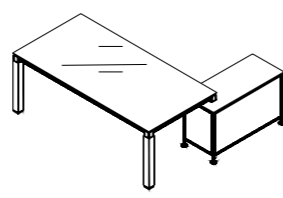

PG-EXC-180-90L

COMPLEMENTARIOS O-RACK

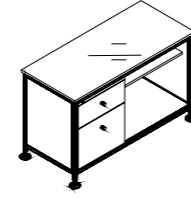

OX-140-S

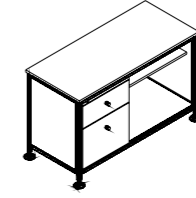

OX-140-W

PALETTE MADERA

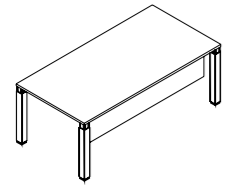

PW-EXC-200-100

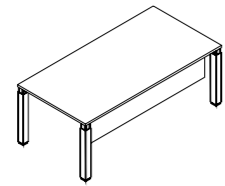

PW-EXC-180-90

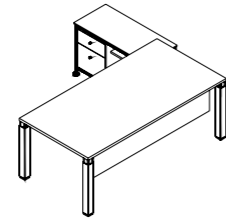

PW-EXC-200-100L

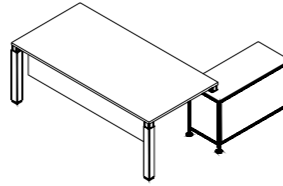

PW-EXC-180-90L

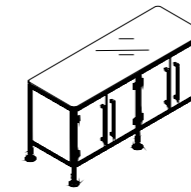

OX-170-G

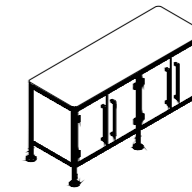

OX-170-W

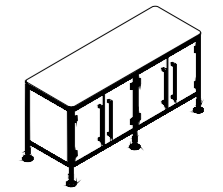

OX-170-S

PALETTE JUNTAS

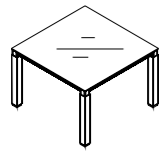

PG-MJP-110

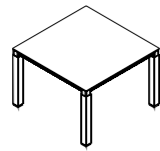

PW-MJP-110

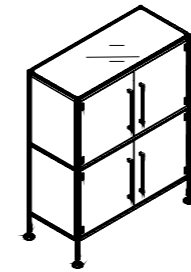

OX-180-G

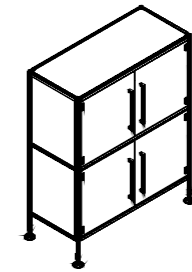

OX-180-W

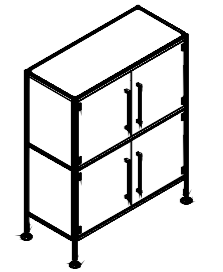

OX-180-S

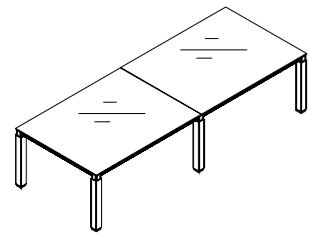

PG-MET-310

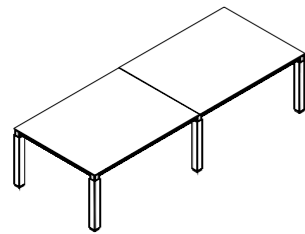

PW-MET-310

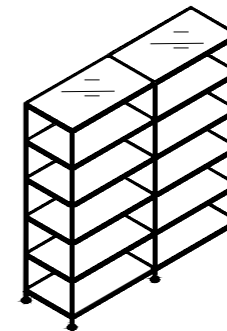

OX-220-G

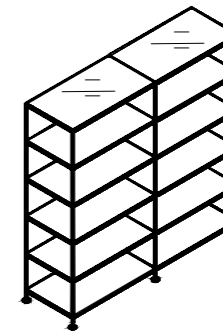

OX-220-W

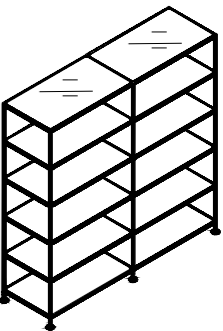

OX-220-S

PALETTE MESAS DE CENTRO

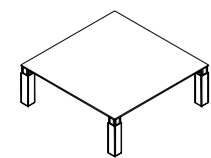

PG-MRP-110

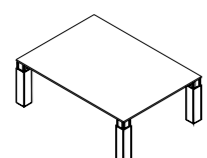

PW-MRP-80

~
Operative Area

- ~
Slim Palette
Vitta
ABC
Ix system
Miura
A-plus
Partition

A-plus + Executive System



~
Meeting Area

~
Tabelle
Slim Palette
Vitta
Palette
Miura
A-plus

Tabelle + Meeting



Sea como mesa de trabajo individual o configurado como puestos múltiples de trabajo, Slim Palette presenta un extenso abanico de posibilidades para que el cliente diseñe su oficina personalizada según su dinámica de trabajo y necesidades.

-Either individual or table set as multiple workstations, Slim Palette presents a wide range of possibilities for the custom design your office by dynamic working and needs.

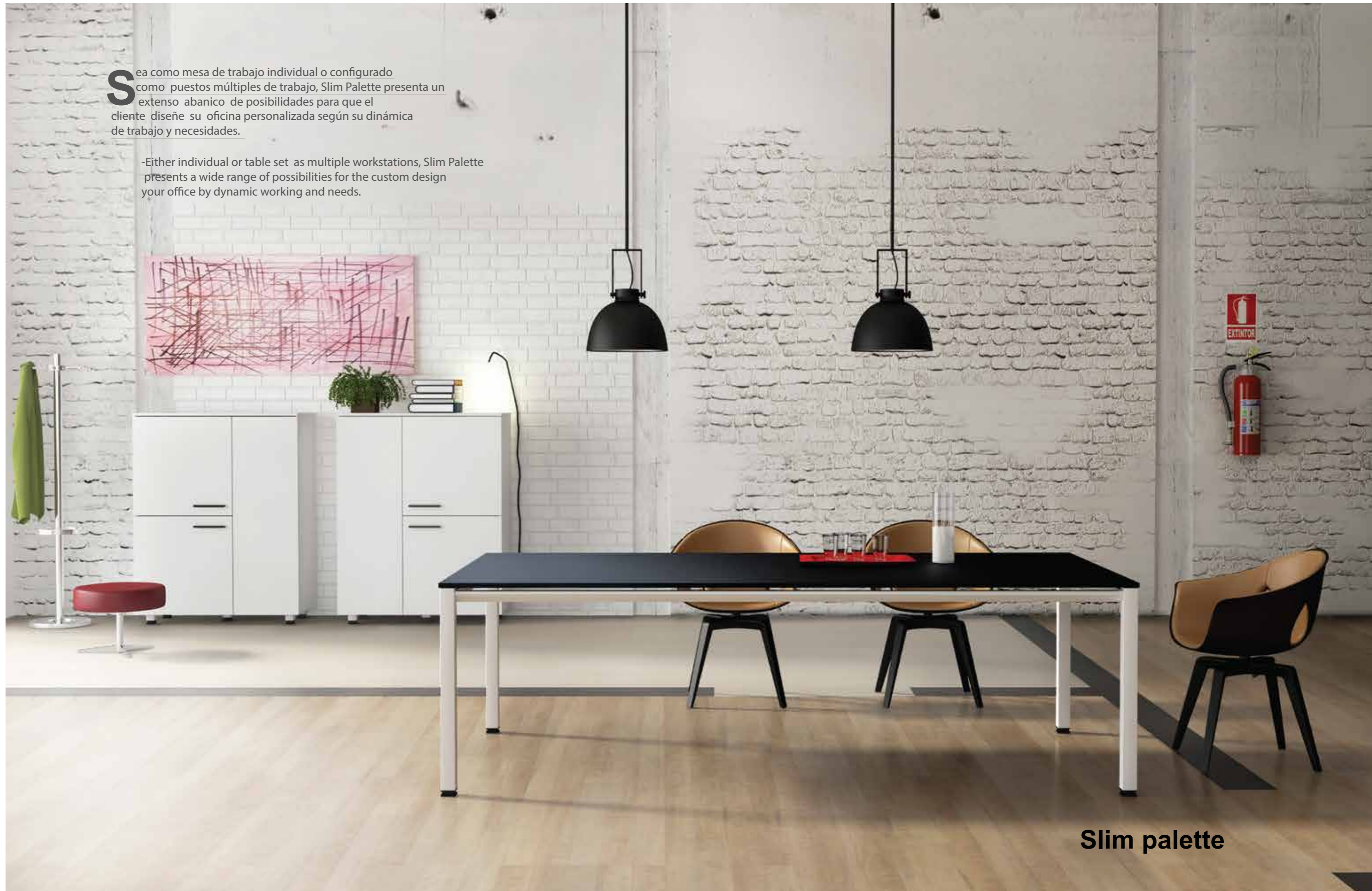

Slim palette



Palette + Meeting



Vitta + Meeting

Miura + Meeting



A-plus + Meeting



La flexibilidad y elegancia pura de Slim Palette, un proyecto transversal que introduce en la oficina un nuevo nivel de estética, la solución de las más diferentes necesidades de espacio y trabajo. Las mesas, cubiertas por el marco perimetral con el plan integrado puede estar equipado con separaciones pantallas y complementado con cajoneras, porta CPU y otros accesorios.

Flexibility and sheer elegance for Slim Palette, a cross project that introduces in the office a new level of aesthetics, resolving the most different needs of space and work. The tables, covered by the perimeter frame with integrated plan can be equipped with separating screens and supplementes with drawers, CPU holders and other accessories.



~
Welcome Area
~
Table
Vitta
Palette

Tabelle





Vitta



Miura



Una oficina sencilla y funcional slim palette combina la ligereza de la estructura con el color blanco, para realizar composiciones operativas y directivas de gran encanto y elegancia, integrada con pantallas en melamina, cristal o tela.

Slim Palette + operative system.



Slim Palette + operative system.



software¹¹

the logic of the slim palette platform

manufacturing
shipping
installation
facility management
cost of ownership
customization
differentiation
environment
flexibility
quality
aesthetics



1+1

SLIM PALETTE
DESIGNING HARMONY

Colin ha desarrollado Slim Palette, un sistema de trabajo que nace como respuesta a los requisitos actuales de los usuarios y las empresas, que demandan ergonomía y operatividad, y al mismo tiempo buscan rentabilizar al máximo la inversión realizada y optimizar el espacio de la oficina. Sencilla en líneas y prestaciones.

Colin has developed Slim Palette a desking system that has been created as an answer to the current requirements of users and companies, who demand ergonomics and efficiency, while at the same time seeking to maximize the profitability of the investment and optimise's office. Simple lines and features.

Sea como mesa de trabajo individual o configurado como puestos múltiples de trabajo, Slim Palette presenta un extenso abanico de posibilidades para que el cliente diseñe su oficina personalizada según su dinámica de trabajo y necesidades.

-Either individual or table set as multiple workstations, Slim Palette presents a wide range of possibilities for the custom design your office by dynamic working and needs.

TIMELESS DESIGN



ARCHITECTURE & THE OFFICE





Minimalist and lightweight.

La flexibilidad y elegancia pura de Slim Palette, un proyecto transversal que introduce en la oficina un nuevo nivel de estética, la solución de las más diferentes necesidades de espacio y trabajo. Las mesas, cubiertas por el marco perimetral con el plan integrado puede estar equipado con separaciones pantallas y complementado con cajoneras, porta CPU y otros accesorios.

Flexibility and sheer elegance for Slim Palette, a cross project that introduces in the office a new level of aesthetics, resolving the most different needs of space and work. The tables, covered by the perimeter frame with integrated plan can be equipped with separating screens and supplemented with drawers, CPU holders and other accessories.

“if you invest in beauty,
it will remain with you
all the days of your life”

Frank Lloyd Wright (1867-1959)



Compartimiento eléctrico voz y datos
- power and data access
- électrique de voix et de données
compartiment

Pantallas: tela, cristal, melamina
- screens: fabric, glass, melamine
- écrans: tissu, verre, mélamine

Cubiertas: melamina, cristal
- top: melamine, glass
- plateau: mélamine, verre

Estructura de aluminio
- aluminium structure
- structure en aluminium

Riel porta accesorios
- rail fittings
- barre à accessoires



Cajoneras móviles 1 + 1, 2 + 1
- drawer mobile 1 + 1, 2 + 1
- caisson mobile 1 + 1, 2 + 1

Una oficina sencilla y funcional slim palette combina la ligereza de la estructura con el color blanco, para realizar composiciones operativas y directivas de gran encanto y elegancia, integrada con pantallas en melamina, cristal o tela.

_A simple and functional office but, above all, bright! Slim Palette combines the lightweight structure with white for general and executive office compositions that are very attractive and elegant, integrated with melamine, glass or fabric screens.

_Un bureau simple et fonctionnel, mais surtout lumineux! Slim Palette assortit la couleur blanche à la légèreté de la structure, afin de réaliser des compositions opérationnelles et de direction très fascinantes et élégantes, intégrées avec des écrans en métacrylate ou en verre.



Minimalist and lightweight.



The fascination of simplicity.

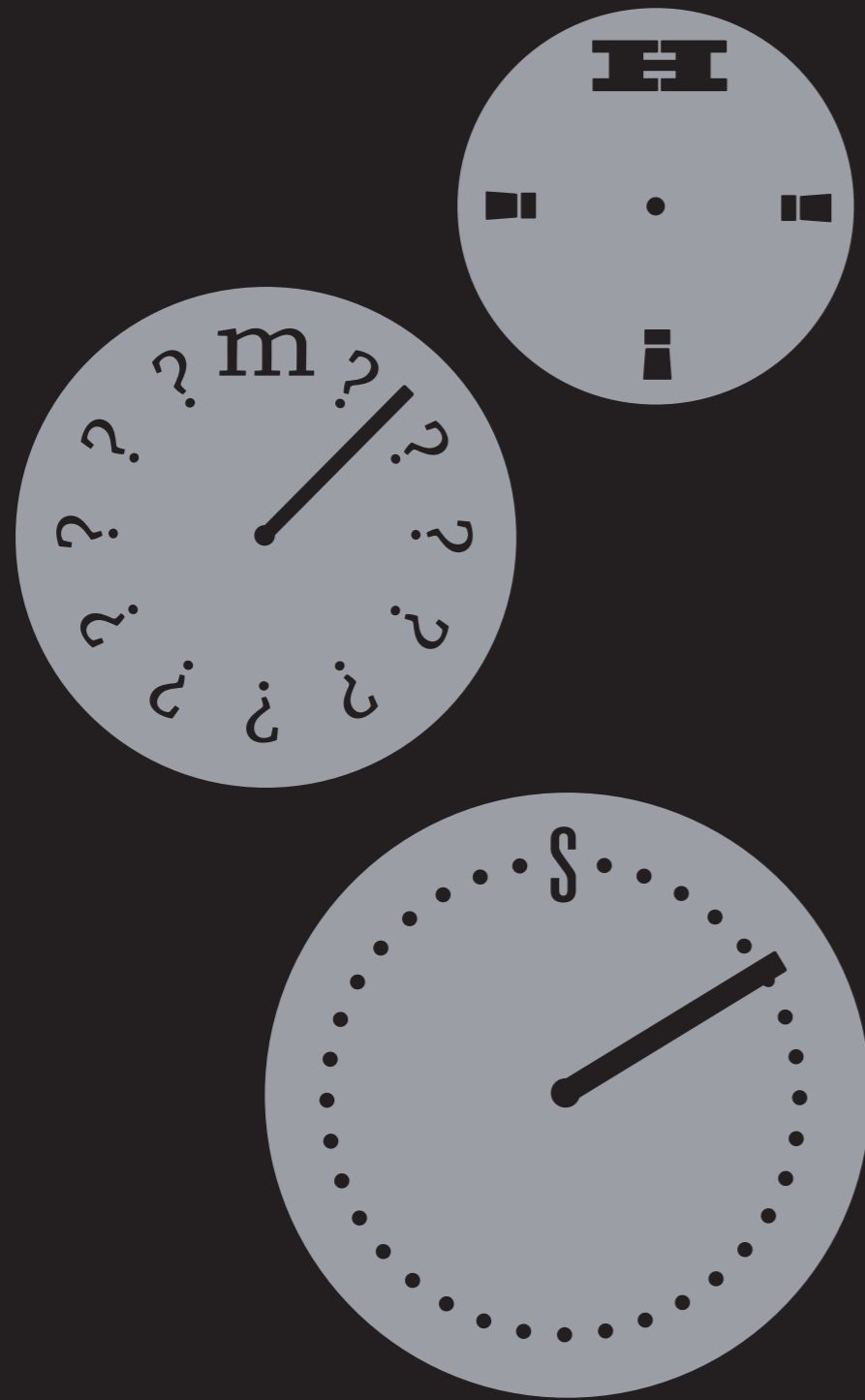

“IT’S ALL ABOUT
MOVEMENT EVERY
MOVEMENT IS AN
OPTION,
EVERY OPTION,
A CONNECTION OF
MOVEMENTS!”

Tomadores de decisiones

Si los que toman las decisiones exigen un alto grado de responsabilidad, los conjuntos ejecutivos deberían de favorecer lo mejor posible a los procesos de decisión y votación que les permitan dirigir mejor la empresa en base a objetivos fijados.

La funcionalidad de la instalación de los conjuntos directivos es tan importante como su acabado de alta calidad, ya que los conjuntos ejecutivos simbolizan el rango que se le confiere a este gremio dentro de la organización. Por ello se emplea aquí estructuras de aluminio pulido y, cubierta en chapa de maderas finas y cristales de seguridad cuya precisión y elegancia son inconfundibles.

Decision makers

If decision makers require a high degree of responsibility, executive sets should to promote the best decision-making and voting. for example using a table whose sides istalacion rounded encourage interaction and inter change of meeting participants. The exposed places on the front sides allow better targeting based on company objectives.

The functionality of the installation of officers for suit is as important as its high quality finish as executive sets symbolize the range that gives this guild within the organization. So here is used polished aluminum structures, covered in fine wood veneer and security windows whose precision and elegance is un mistakable.

Slim palette un sistema ejecutivo, que nace como respuesta a los requisitos actuales de los usuarios y de las empresas que demandan ergonomía funcionalidad y belleza.

- flow is a state of productive harmony where motivation and attention get together.





Equilibrio entre innovación, calidad, confort y representatividad, estas son las características principales de Slim Palette. Como en los mejores proyectos, se unen la sabiduría artesanal, diseño y tecnología, el resultado es un producto de inconfundible identidad y carácter.

*„That the h
play goes on and
my contribute a verse,
Math will your ve*

„The main Slim Palette character is the balance between quality and innovation, comfort and representation. As it happen in the best projects, craftsmen knowledge, design and technology gather one to the other, the result is a product of unique identity and character.

DRAWERS, CAJONERAS Y LIBREROS:

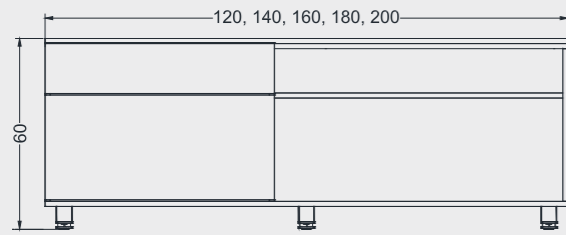

Lateral CUEX-120, cuex-140, CUEX-160, CUEX 180, CUEX-200 lateral para escritorio y/o estaciones de trabajo fabricada en acero con tapa y frentes en melammina, cristal y/o chapa de madera. 1 cajon papelerero y una gaveta.

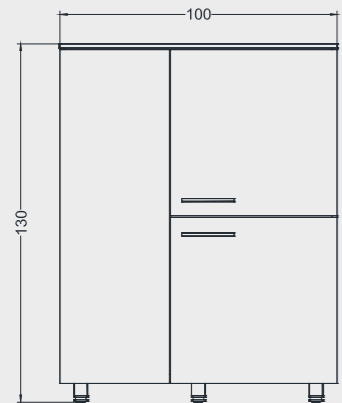

Librero VTLB-001
Librero fabricado en cuerpo en lamina de acero colores: blanco, negro y gris frentes y tapa superior: laminado plastico y/o chapa de madera.

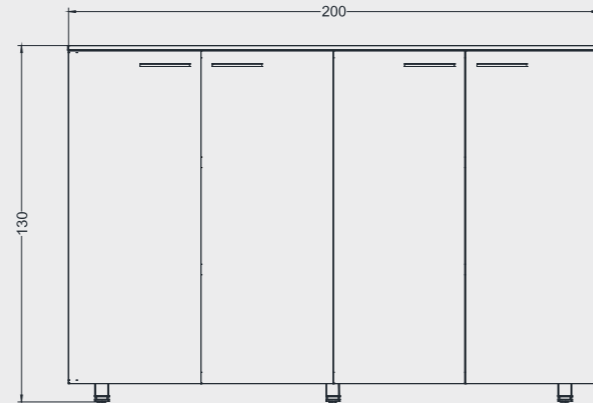

Librero de 4 pueras VELB-004

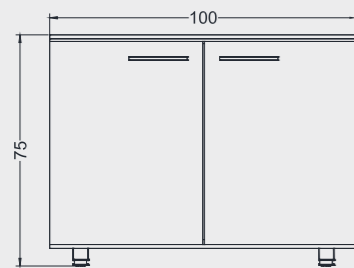

Credenza VTCR-02
credenzas en 2, 3 y 4 puertas fabricadas: cuerpo en lamina de acero, colores: blanco, negro y gris. frentes y tapa superior: laminado plastico y/o chapa de madera.

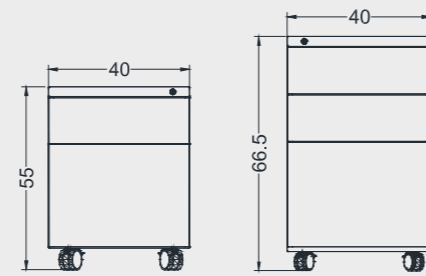

Cajoneras moviles y fijas.

WORKSTATIONS, ESTACIONES DE TRABAJO:

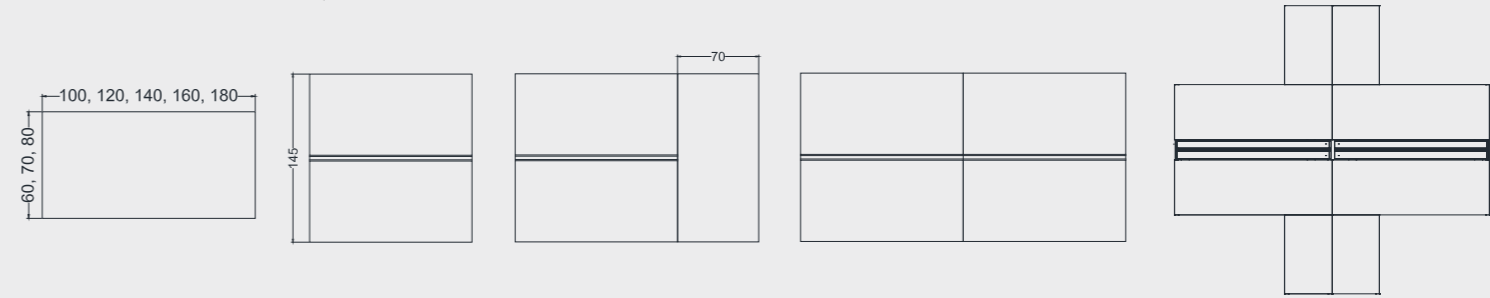

EXECUTIVE DESCK, ESCRITORIO EJECUTIVOS:

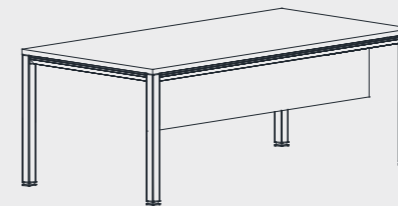

SPTG180 F180 D80 H75
SPTG190 F190 D80 H75
SPTG200 F200 D100 H75

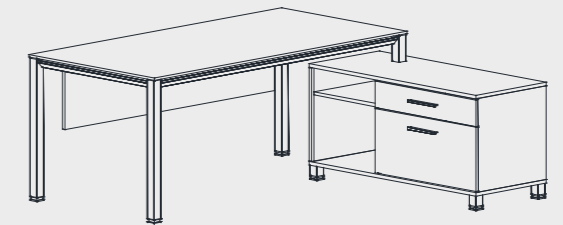

SPGL160-160 F160 D160 H75
SPGL180-180 F180 D180 H75
SPGL200-180 F200 D180 H75

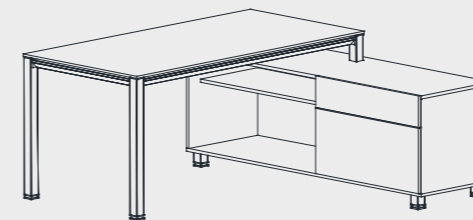

SPTG180 F180 D80 H75
SPTG190 F190 D80 H75
SPTG200 F200 D100 H75

PANTALLAS, SCREENS

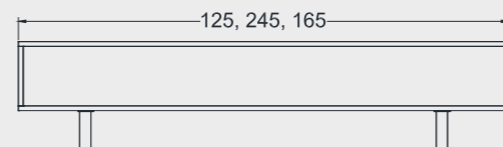
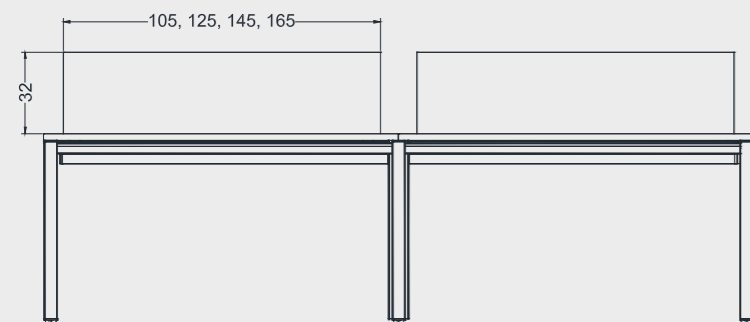

Estante abierto.

FINISHES, ACABADOS:

Top, Cubiertas.



Frame, Estructuras.



Sea como mesa de trabajo individual o configurado como puestos múltiples de trabajo, Vitta presenta un extenso abanico de posibilidades para que el cliente diseñe su oficina personalizada según su dinámica de trabajo y necesidades.

Whether used as a single desk or configured as multiple user workstation, Vitta offers a wide range of possibilities so that the customer can design his office according to work dynamics and needs.
Flexibility and versatility for today's office.



Vitta + operative system.



Vitta + operative system.

ABC + operative system.





IX + operative system.



Miura + operative system.



A-plus + operative system.



PA partition + operative system.



PA partition + operative system.



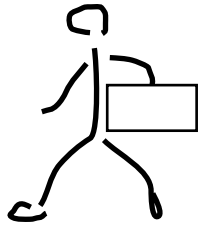

Traveler

So-called travelling salesman of e-commerce, beyond the compass of office block and time, and communicate the medium by information of activity and communication etc. and shuttle in the world-wide locations, play as a role to consult, negotiate, and investigate. The way they work, is also characteristic for them to work.

Walker

Project manager, office secretary, desk clerk and general administration...such kind of person in charge of business matters with personnel of each section contain close contact, and need to often go back and forth each unit to proceed the communication, moderated to wait for the work with service.

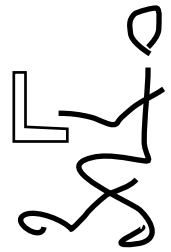
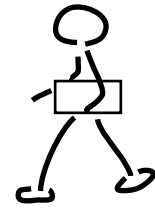

Sitter

Be engaged in the immobile routine procedure, and generally dealing with repetition and hand over to do business of administration, communicated with the outside world by many adoptions of method of computers, telephone, FAX and the e-mail...etc. The nature of work is pure without changing.

Runner

People who manage external affairs, 1/3 time is transacting the administrative matters, 2/3 times contact the customer, out of office building; they pay much attention to the good flexibility of workspace.





Short time workstation

Modernized office furniture masters the esthetics of environment between movement and stillness. The decrease of the replacement cost can create the infinite value in the restricted space. The perfect integration of the storage system and information facilities in the Short Time Workstation, providing the work style of Stand-by, can cater the individual need instantaneously and command the efficiency.





Personal Mailbox Cabinet Flexible space and nimble application, the office furniture with high mobility can promote the efficiency and vitality of the business.

Movable Multi-function Cabinet

Flexible personal-multi-function cabinet is the spirit to activate the storage of the space.

Special space arrangement with lifted panel is for personal mailbox and archives; stationary can be collected in the drawer; documents in A4 or B4 size can be hung in the hanging drawer; the sortation of archives is well-regulated.





120°

The herringbone professional workstation whit 120° can provide the user the reasonable and comfortable work area.

The consideration of the perfect wire arrangement, environmental lighting and united storage spreads out the crystal of the wisdom of the science and technology in humanity sufficiently.





Our Mobilized Design Extends Space Efficiency

Besides possessing a bright and sturdy structure, the P@ partition workstation introduces a sophisticated peripheral system including curved overhead storages, bookshelves, clothing racks, lamps, stationery trays, etc. The P@ partition system also comes with three types of mobile pedestals. They can be used and moved easily to optimize your working space.

Open type Mobile Cabinet

The newly-designed open type mobile cabinet is convenient for the filing of data. An elaborate handle can help you move the cabinets easily and therefore improve the mobility of your office.



Mobile Cabinet with Rolling Board

The rolling door of the upper box is easy and convenient to lift. In addition, there is a secure lock to ensure the safety of your documents. The lower box is an open space to store folders.



Computer Cabinet with Adjustable Top Board

Computers, documents and diskettes can be put into the cabinet. The top board can be easily adjusted at seven different levels. By adjusting



the top board to the highest level, you can employ it as an additional work surface to put your monitor and keyboard. Or you can lower the top board to the lowest level to hide the cabinet under the desk.

The partition system collocated
freestanding table and
movable furniture can establish
the communication space with flexibility
and efficiency.



Coated Cover
With punched-hole panels or a fabric
cover if you prefer to demonstrate the
sens of ultimate quality and grasp the
trend of times.



The Pleasure of Transmission



Comunication Starts in Convenience

Communication is the bridge between people. A warm and comfortable office enviroment adds harmony as well as improves efficiency.





Room in Room

The design concept of "Room in Room" in the space creates the spacial aesthetic of open and closed. The simple and smooth sliding door can change the space to exclusive halfopened private room easily, and perform the new pattern of the modern office.



Attentive services is the spring of an enterprises. Amiable attitude, a swet smile and warm atmosphere make customers feel respected and construct the furniture of an enterprises. P@ partition system is created to meet the needs of enterprises. Within the space of P@, work is enjoyable, service bring business, and companies can achieve high or levels of performance.

Service Bring Business
Oportunities.



PAH high partition system

The integrated system office furniture.

Systematized sectional partition, for reception, workstation, conference room and executive room
Aluminium alloy frame with special knit grain coating, The structure combined steadily with floor, wall and ceiling, Conveniently wire managing in the inside of the partition.



Systematized
and economical

High partition can be combined with screen, and collocated with suspension accessories, fully utilizes the space, increasing the gradation of the space and building visual aesthetic of the environment.

Flexibility and aesthetics

Division of the Golden Proportion shows the aesthetic of vision; various combinations of panels, collocated hundreds of colors, created the more plentiful working spaces; flexible space planning establishes unlimited possibility of the office.







PEL

TELA / RIDGE COVER
/ FUEL LEATHER /
SAVE LEATHER

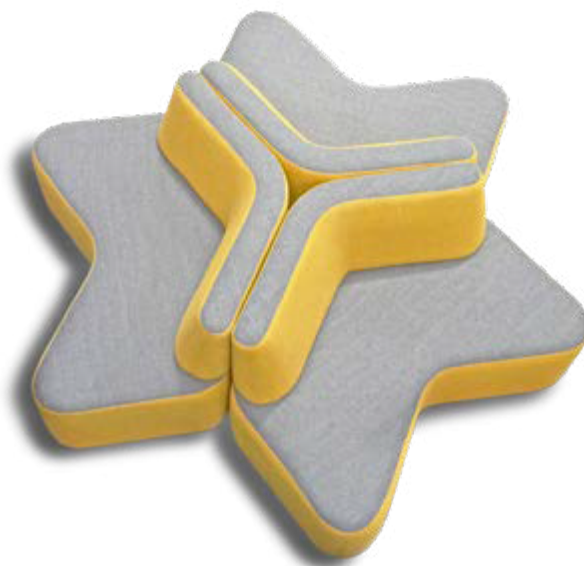



TELA / BUCC COVER
/ FEEL LEATHER /
SAVE LEATHER



TELA / TISSU COVER
/ FEEL LEATHER /
SAVE LEATHER

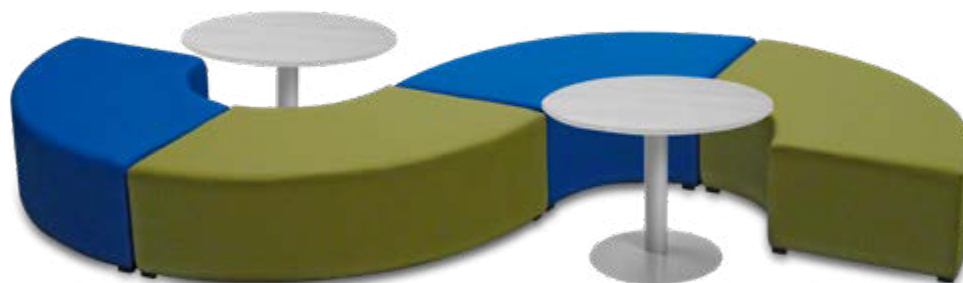
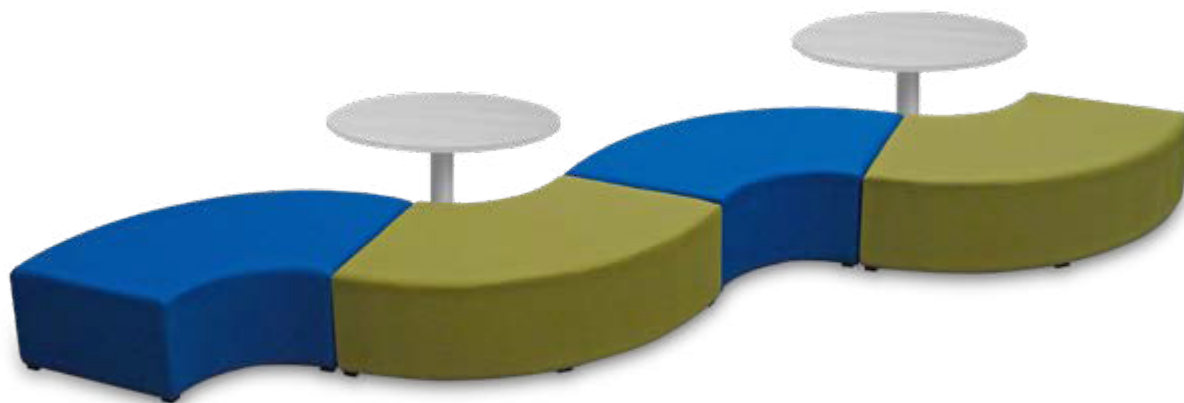

TELA / BUQUE COVER
/ FEEL LEATHER /
SAVE LEATHER



TELA / BUDE COVER
/ SUELL LEATHER /
SAVE LEATHER



PIEL

TELA / SUEDE COVER
/ FUEL LEATHER /
VINYL LEATHER



TELA / BUQUE COVER
/ FEEL LEATHER /
SAVE LEATHER

2 8 2 8 7286274632981901823647821910009927635624141524516
64 9 3840007 6407632739000 746287340170007364470394400400
1 5 2 0 1 8 7398214090 0773000000476239874602976466403947907
8 7 8 4679839000004308484200273900347820023789298227818653
2 5 6 4 80 12878 36445010109782764876472001728645871010327
70 9 1 937 0923745 8997503952984 910932745691283691032847
1 5 7 2 1 9 8 3 7 2 8 6 2 7 4 6 3 2 9 8 1 9 0 1 8 3 6 4 7 8 2 1 9 1 0 0 0 9 9 2 7 6 3 5 6 2 4 1 4 1 5 2 4 5 1 6
7 6 4 9 3 4 0 0 7 3 6 0 7 6 2 7 3 9 0 0 0 3 7 4 6 2 8 7 3 4 0 1 7 0 0 0 7 3 6 4 4 7 0 3 9 4 4 0 0 4 0
1 8 7 2 9 0 1 1 8 2 7 3 8 2 1 4 0 9 0 0 7 7 3 0 0 0 0 0 4 7 6 2 3 9 8 7 4 6 0 2 9 7 6 4 6 6 4 0 3 9 4 7 9 0 7
8 7 8 4 7 9 8 3 9 0 0 0 0 0 4 3 0 8 4 8 4 2 0 0 2 7 3 9 0 0 3 4 7 8 2 0 0 2 3 7 8 9 2 9 8 2 2 7 8 1 8 6 5 3
2 5 4 6 3 3 8 7 9 6 7 1 0 1 0 9 7 8 2 7 6 4 8 7 6 4 7 2 0 0 1 7 2 8 6 4 5 8 7 1 0 1 0 3 2 7 6 7 8 9 7 9 7 8 9 9
8 7 2 3 0 9 3 7 4 0 9 2 3 7 4 5 0 9 7 5 0 3 9 5 2 9 8 4 6 9 1 0 9 3 2 7 4 5 6 9 1 2 8 3 6 9 1 0 3 2 8 4 7
26 29 3840 073 407 3273900003746287340170007364470394400400
7 3 901 9 273943094387626 4235000000047623987460297646640399
6 7 3 7 4 8 7 7 3 8 9 0 9 0 4 3 0 8 4 8 4 2 0 0 2 7 3 9 0 0 3 4 7 8 2 0 0 2 3 7 8 9 2 9 8 2 2 7 8 1 8 6 5 3
0 5 0 2 9 1 0 9 7 4 0 9 2 3 7 4 5 0 8 9 7 5 0 3 9 5 2 9 8 4 6 9 1 0 9 3 2 7 4 5 6 9 1 2 8 3 6 9 1 0 3 2 8 4 7
5 7 2 3 7 2 8 6 7 4 6 3 9 8 1 9 0 1 8 2 3 6 7 8 2 1 9 1 0 0 0 9 9 2 7 6 3 5 6 2 4 1 4 1 5 2 4 5 1 6
26 2 0 3 8 4 0 0 7 3 6 4 0 7 6 3 2 7 3 9 0 0 0 3 7 4 6 2 8 7 3 4 0 1 7 0 0 0 7 3 6 4 4 7 0 3 9 4 4 0 0 4 0
6 3 90 1 9 8 2 7 9 8 2 1 4 0 9 0 0 0 7 3 0 0 0 0 0 4 7 6 2 3 9 8 7 4 6 0 2 9 7 6 4 6 6 4 0 3 9 4 7 9 0 7
7 3 7 4 7 8 3 9 0 0 0 0 4 3 0 8 4 8 4 2 0 0 2 7 3 9 0 0 3 4 7 8 2 0 0 2 3 7 8 9 2 9 8 2 2 7 8 1 8 6 5 3
6 3 5 3 6 8 7 9 4 6 0 1 0 1 0 9 7 8 2 7 6 4 8 7 6 4 7 2 0 0 1 7 2 8 6 4 5 8 7 1 0 1 0 3 2 7 6 7 8 9 7 9 7 8 9 9
8 0 9 3 1 9 7 4 0 9 2 7 4 0 8 9 7 5 0 3 9 5 2 9 8 4 6 9 1 0 9 3 2 7 4 5 6 9 1 2 8 3 6 9 1 0 3 2 8 4 7
3 26 2 3 40 073640763273 0003746287340 70007364470394400400
1 5 2 0 1 9 8 7 3 9 4 3 0 9 4 3 8 7 6 2 6 4 4 2 3 5 0 0 0 0 0 4 7 6 2 3 9 8 7 4 6 0 2 9 7 6 4 6 6 4 0 3 9 9
8 2 5 4 8 8 0 0 1 2 8 8 3 6 2 0 9 8 9 7 3 7 6 5 4 2 7 6 4 8 7 6 4 7 2 0 0 1 7 2 8 6 4 5 8 7 1 0 1 0 3 2 7
2 5 0 9 3 1 0 3 7 4 0 9 2 3 7 4 5 0 8 9 7 5 0 3 9 5 2 9 8 4 6 9 1 0 9 3 2 7 4 5 6 9 1 2 8 3 6 9 1 0 3 2 8 4 7
7 6 2 0 3 4 0 0 7 6 4 0 6 3 2 7 3 0 0 0 3 7 4 6 2 8 7 3 4 0 1 7 0 0 0 7 3 6 4 4 7 0 3 9 4 4 0 0 4 0
7 3 90 1 9 8 2 7 9 8 2 1 4 0 9 0 0 0 7 7 3 0 0 0 0 0 4 7 6 2 3 9 8 7 4 6 0 2 9 7 6 4 6 6 4 0 3 9 4 7 9 0 7
1 6 8 4 6 4 7 8 0 1 2 8 7 8 3 6 4 4 5 0 1 0 1 0 9 7 8 2 7 6 4 8 7 6 4 7 2 0 0 1 7 2 8 6 4 5 8 7 1 0 1 0 3 2 7
5 2 3 0 9 3 7 2 8 6 2 7 4 6 3 2 9 1 9 0 1 8 2 3 6 4 7 8 1 9 1 0 0 0 9 9 2 7 6 3 5 6 2 4 1 4 1 5 2 4 5 1 6
7 3 2 9 3 7 2 8 6 2 7 4 6 3 2 9 1 9 0 1 8 2 3 6 4 7 8 1 9 1 0 0 0 9 9 2 7 6 3 5 6 2 4 1 4 1 5 2 4 5 1 6
4 90 8 0 0 0 3 6 0 7 6 3 2 7 3 9 0 0 0 3 7 4 6 2 8 7 3 4 0 1 7 0 0 0 7 3 6 4 4 7 0 3 9 4 4 0 0 4 0
8 7 3 3 8 4 7 9 8 9 0 0 0 0 0 4 3 0 8 4 8 4 0 0 2 7 3 9 0 0 3 4 7 8 2 0 0 2 3 7 8 9 2 9 8 2 2 7 8 1 8 6 5 3
8 3 4 3 6 8 9 4 6 7 0 1 0 1 0 9 7 8 2 7 6 4 8 7 6 4 7 2 0 0 1 7 2 8 6 4 5 8 7 1 0 1 0 3 2 7 6 7 8 9 7 9 7 8 9 9
9 9 3 1 9 3 4 0 9 2 3 7 4 5 0 8 9 7 5 0 9 5 2 9 8 4 6 9 1 0 9 3 2 7 4 5 6 9 1 2 8 3 6 9 1 0 3 2 8 4 7
2 8 2 1 8 7 8 6 2 7 4 6 3 2 8 1 9 0 1 8 2 3 6 4 7 8 2 1 9 1 0 0 0 9 9 2 7 6 3 5 6 2 4 1 4 1 5 2 4 5 1 6
4 9 3 4 0 0 0 7 3 6 4 0 7 6 3 2 7 9 0 0 0 3 7 4 6 2 8 7 3 4 0 1 7 0 0 0 7 3 6 4 4 7 0 3 9 4 4 0 0 4 0
1 5 2 0 1 9 8 7 3 9 4 3 0 9 4 3 8 7 6 2 6 4 4 2 3 5 0 0 0 0 0 4 7 6 2 3 9 8 7 4 6 0 2 9 7 6 4 6 6 4 0 3 9 9
1 8 6 8 7 4 7 8 3 8 9 0 9 0 4 3 0 8 8 4 2 0 0 2 7 3 9 0 0 4 7 8 2 0 0 2 3 7 8 9 2 9 8 2 2 7 8 1 8 6 5 3
2 4 5 4 8 0 0 1 2 7 8 9 3 6 2 0 9 9 7 3 7 6 5 4 2 7 6 4 8 7 6 4 7 2 0 0 1 7 2 8 6 4 5 8 7 1 0 1 0 3 2 7